

Winch 12V 1820kg



Instructions for use

Translation of the original instructions

CE

Dear user!

You have become the owner of a Mar-Pol winch. This winch is characterized by maximum safety and easy operation. It is a reliable and high-performance device with quick installation and ready to use.

Although simple to operate, its operation must comply with the requirements contained in this manual and the safety regulations in force in the territory where it is used.

Please read the operating instructions carefully before using the device! Do not dismantle the device. Dismantling may damage the device and also expose the person operating it to danger.

Compliance with the following recommendations will enable safe and long-term use of our equipment.

AFTER READING AND UNDERSTANDING THIS MANUAL, YOU NEED TO LEARN HOW TO USE THE WINCH.

Once the winch is mounted, do a few exercises to learn how to operate the equipment before you actually need to use it.

Do not help yourself while towing the vehicle (using the drive system). The combination of winch and vehicle drive work can overload the winch and rope.

MAINTAIN AN EMPTY ZONE AROUND THE ROPE. Do not allow people to be near the winch while it is in use. ALWAYS STAND AT A SAFE DISTANCE FROM THE ROPE, HOOK AND WINCH. V IN CASE OF DAMAGE TO ANY ELEMENT, IT IS GOOD TO BE OUT OF ITS REACH. CARRY OUT FREQUENT CHECKS ON THE ROPE, HOOK AND THE WINCH ITSELF.

If you touch the rope, wear thick leather gloves. DO NOT LET THE ROPE SLIP IN YOUR HANDS, EVEN IF YOU ARE WEARING GLOVES.

DO NOT GRAB THE HOOK WITH YOUR FINGER AS YOU MAY INJURE YOURSELF OR LOSE A FINGER IF IT BECOMES WEDGED IN THE HOOK. NEVER HOLD OR GUIDE THE ROPE WITH YOUR HANDS - ALWAYS USE A ROPE GRIP.

Never catch the hook directly on the rope as this can destroy the rope. It is recommended linking the strap with an eyelet of corresponding strength to which you can attach the hook.

Winch mounting

During assembly, make sure to use the shims under the base.

Fit the winch to the vehicle support member to ensure that the forces acting on it do not cause it to break away.

WARNING: Take extra care when connecting the battery! The battery may produce flammable gases! Sparks generated when connecting can cause them to ignite!

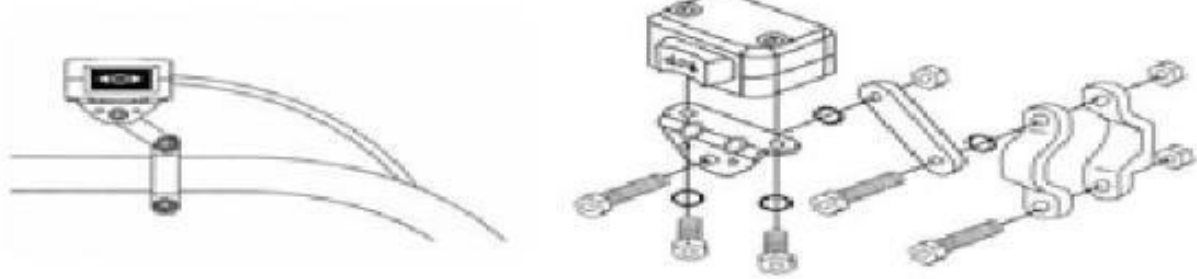

Connection diagram

IMPORTANT: Make sure a fuse has been installed. Failure to have a fuse installed can lead to situations that are hazardous to life and limb. Your winch will also not be protected from overloading or burning.

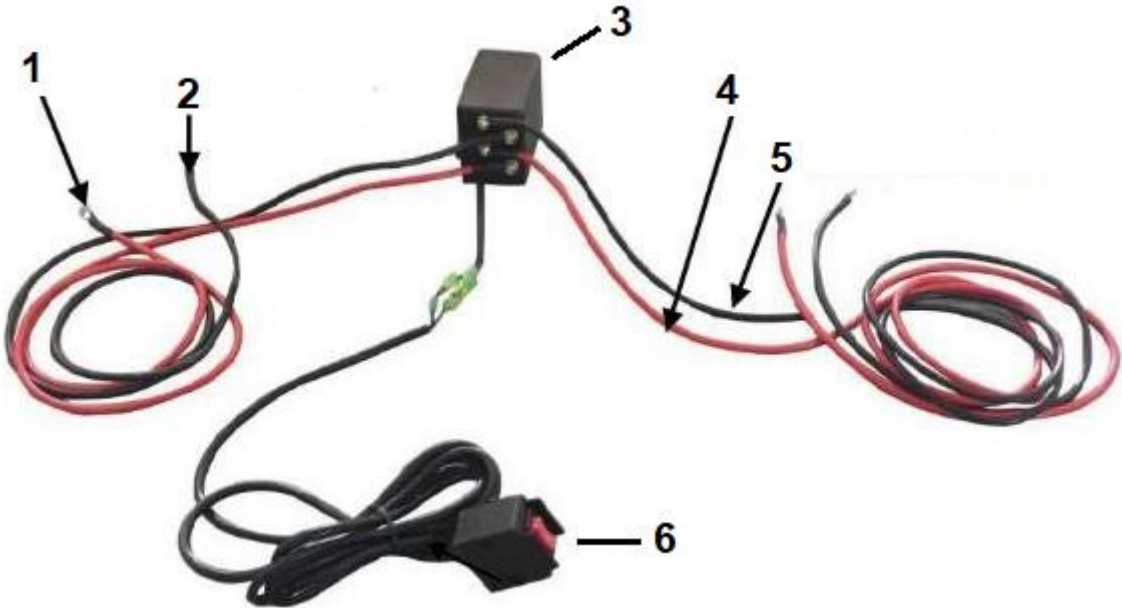

- 1. Connect to the " + " reel
- 2. Connect to the " - " reel
- 3. Control box
- 4. Red to plus battery
- 5. Black to the minus battery
- 6. Wired remote control

Operation of the winch

SAFETY RULES

Failure to observe the warnings below and interference with the design of the equipment shall relieve the manufacturer of liability for damage to persons caused by his work, animals and property, or the equipment itself, and voids warranty rights.

- a) The user cannot exceed the maximum parameters for which the device was manufactured.
- b) Before switching on, make sure that the power cord and other elements of the device are in good condition.
- c) Always wind the rope from the underside of the winch drum.
- d) Do not load the equipment with loads close to the maximum load for extended periods of time.
- e) Do not leave the winch on if the engine has stopped due to overload. If the motor stops, turn off the power immediately.
- f) The vehicle engine should be switched on while the winch is working to reduce the current consumption of the battery and increase the strength and speed of the winch.
- g) For loads greater than $2/3$ of the maximum load, it is recommended to use a pulley in order to release the rope. This reduces the effective winch load and rope tension by approximately 50%.
- h) Carry out frequent inspections of the rope and winch, frayed rope with protruding fibers should be immediately replaced with rope of the same parameters with the data in the table. For
When touching the rope, wear thick, leather gloves and do not let the rope slide over your hands.
- i) Regularly check the winch attachment to make sure all bolts are tightened securely.
- j) Do not use the winch if there are less than 5 turns of rope left on the drum, as the rope attachment may not be able to withstand the load.
- k) Never attach the hook against the rope as this destroys the rope. Use a special strap, it is recommended to connect the strap with an eyelet of adequate strength to which the hook can be attached.
- l) Place a heavy blanket or jacket on the rope around the hook. In the event of damage to the rope, the material acts as a shock absorber, dampening the impulse of the rope impact. Raise the bonnet of the vehicle for additional protection.
- m) Only use the winch when you have an unobstructed view of the entire field of vision from the hook to the vehicle.
- n) Accessories such as buckles, pulleys, straps should be carefully selected for the tensile load of the winch in question and should be checked regularly. Even minor damage can reduce their strength.
- o) Never overtighten the rope release lever while the rope is taut.
- p) Do not use the reel under water. Never allow the winch to be flooded with water.

q) Do not allow the rope to twitch.

WARNING! Never touch the rope with bare hands, use thick leather gloves. Use a grip to tension the rope. Do not allow the rope to stretch over your hands.

Unwinding the rope

1. Releasing the clutch

In order to release the rope, pull the pull rod and then turn it so that it does not return to its position.

Clutch locking is done in reverse order.

WARNING: If the clutch is loose, never release the winch! This will damage the drive gears.

IMPORTANT: After locking the clutch, pull on the rope until you hear a characteristic "click". This will help keep the gears in good condition and prevent jerking.

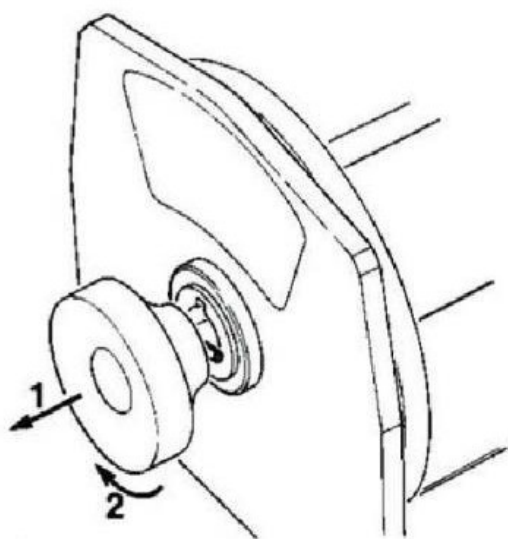

Loose clutch

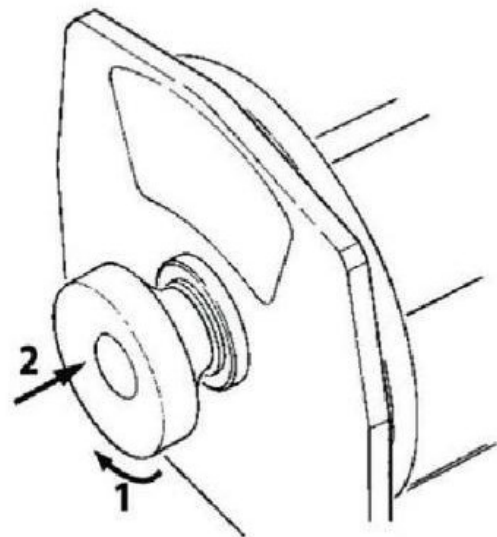

Blocked clutch

2. Never use your hands to unwind the rope! This causes danger. A grip is used for this purpose.

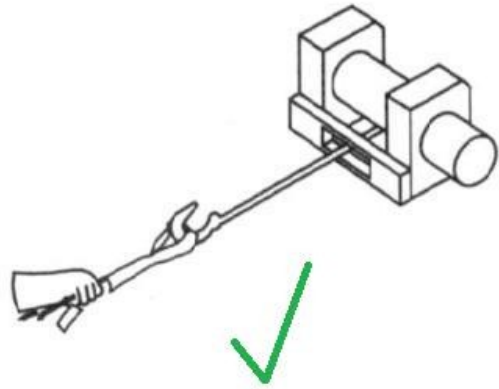
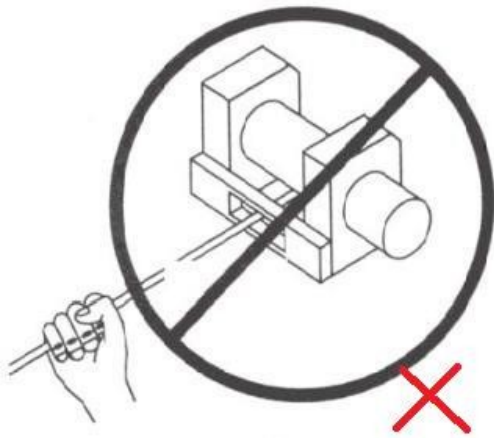

3. Rope fixing

a) Do not choose trees for fixing, they could be damaged and may not be able to withstand the load applied, which could lead to the tree tipping over onto the towing vehicle. If necessary, use a wide belt. Also make sure that the tree selected can withstand at least twice the applied load.

b) Never catch the hook directly on the rope, it could be damaged.

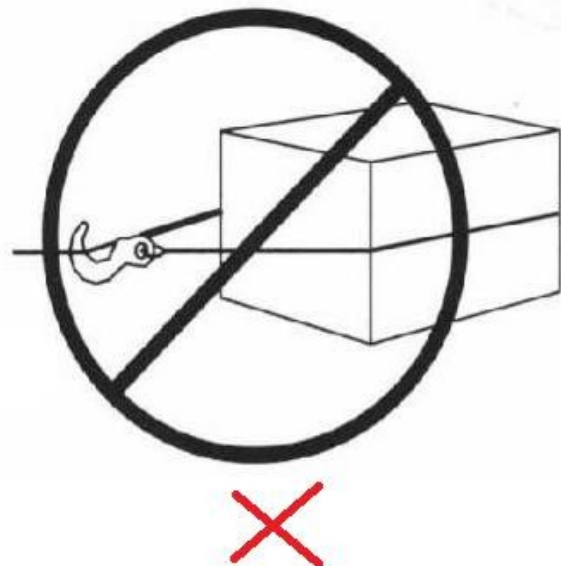
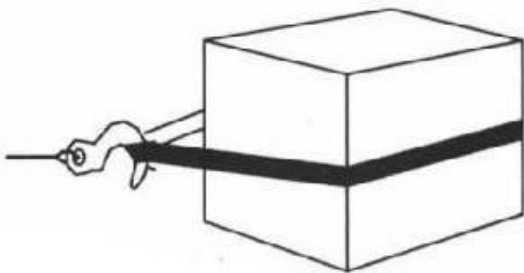

4. Working with the winch

Press the button on the remote control to start the winch.

According to the direction of the arrows on the remote control, the winch will start winding or unwinding the rope.

IMPORTANT: Make sure the clutch is fully locked before pressing the button (page 4).

NOTE: We recommend that you practice operating the winch before actually needing to use it.

DANGER: It is recommended to throw a blanket or other material over the winch rope while the winch is in operation. If the rope breaks, this will help reduce the force accumulated in the rope.

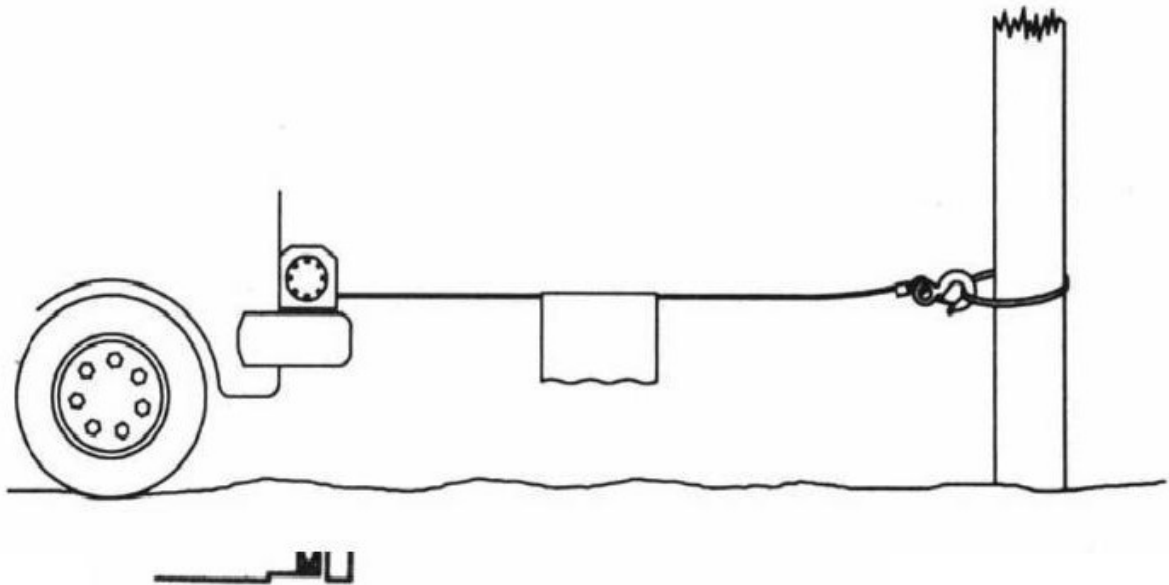

Try to work at high rope angles when towing the vehicle.

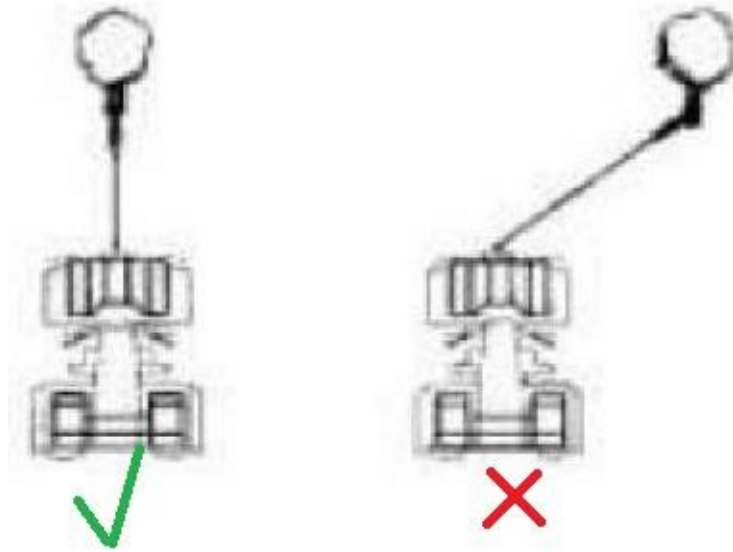

Keep in mind that the rope must be wound on the drum straight, so as not to tangle the rope, this could damage it.

DANGER: Do not bring your hands or other body parts close to the winch drum when operating the winch! There is a huge risk of hands being pulled in.

5. Working with pulley (optional accessory)

Fitting a pulley will increase the force of the winch but reduce the winding speed. It should be mounted according to the figure below.

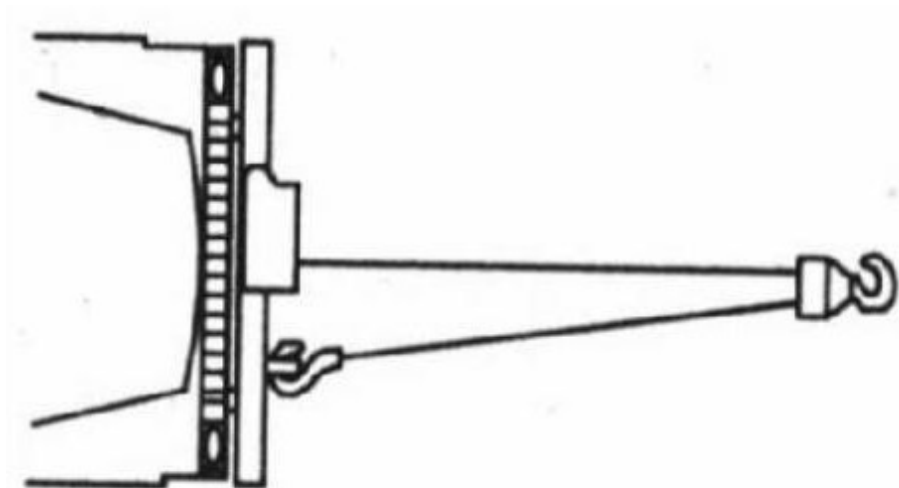

6. Winch design

TECHNICAL PARAMETERS

Specification: **M80801,**
M80800

Maximum tensile load: 4000 lbs/one rope (1814 kg)

Motor: permanent magnet, 0,8 kW/1,1 hp 12V

Gear ratio: 128:1

Gearbox type: 3-speed planetary

Clutch: cam activated

Rope thickness / length: ,4mm / 15 m (steel) 6
mm / 13 m (synthetic)

Drum (diameter x width): 1.77" diameter x 3.19" (45 mm diameter x 81 mm)

Overall dimensions: 13.6" x 4.6" x 4.8" (345 mm x 118 mm x 121 mm)

Weight: net/gross: 25 kg/27 kg

SCHEDULE

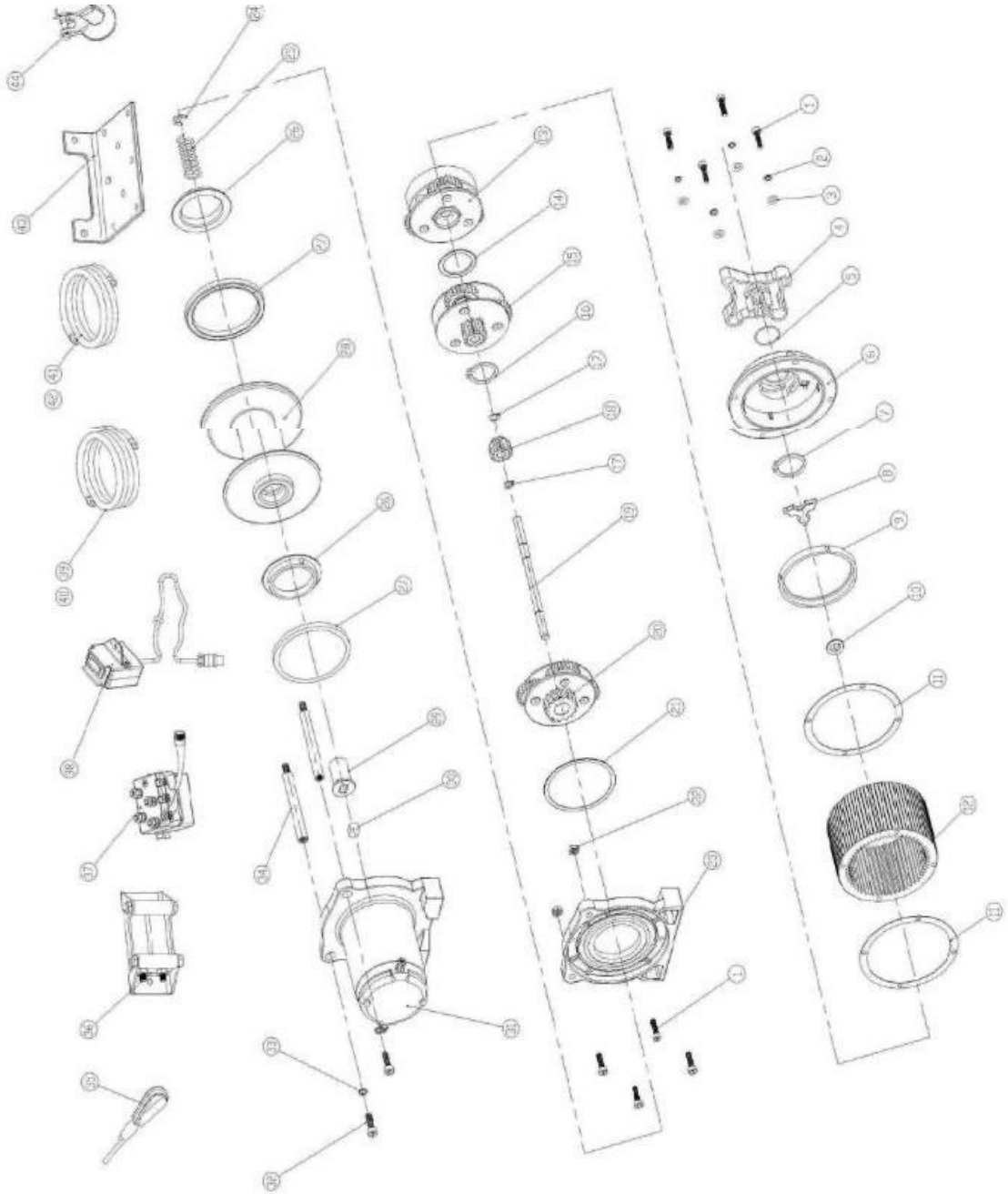

Warranty conditions

In accordance with Act No. 136/2002 Coll., the product purchased by you is guaranteed for a period of 24 months from the date of sale. In the case of purchase of goods used for trade or business, the warranty period is 12 months. The warranty is provided only if the products are used in accordance with the operating instructions and the method of use.

All parts subject to natural wear and tear, overloading, use of the product for purposes other than those for which it is intended, and defects in transportation are excluded from the warranty,

or improper (unprofessional) handling. We consider improper handling to be an example where the operating instructions and the generally binding regulations for working with the product have not been followed. Similarly, an attempt at unprofessional repair beyond recommended maintenance is also assessed.

The warranty applies exclusively to defects caused by defects in materials, manufacturing assembly or processing technology.

The right to invoke the guarantee shall be extinguished:

- 1) the product has not been used in accordance with the operating instructions
- 2) any intervention has been made in the machine construction without prior written consent of KAXL s.r.o.
- 3) the product has been used in other conditions or for purposes other than those for which it is intended
- 4) a part of the product has been replaced by a non-original part
- 5) damage to the product or excessive wear and tear is caused by inadequate maintenance
- 6) damage caused by external mechanical, thermal or chemical influences
- 7) the defects were caused by improper storage or handling of the product
- 8) the product has been used (for the product type) in an aggressive environment e.g. dusty, humid
- 9) the product has been used in excess of the permissible load

The warranty does not cover items that can be expected to wear out due to their normal function (e.g. wear on carbons, spark plug, etc.)

Use only recommended accessories and original spare parts to operate the products.

Claims should be made immediately upon discovery of the defect with the dealer who sold you the product and enquire about repair options at an authorised repairer. If your the claimed defect is covered by the warranty, you will be invoiced for the work and costs associated with the inspection and assembly and disassembly of the components.

When making claims, submit a properly completed warranty card or other proof of purchase bearing the date of sale.

Hand in the product for repair in a clean condition, properly cleaned, free of dust or dirt. Send the original accessories with the product for an accurate diagnosis of the fault.

When sending by transport service, pour out the unconsumed fuel and oil from the product. Pack the product properly, preferably in the original packaging, so as not to damage it. Damage caused by inadequate packaging cannot be accepted as a warranty defect!

Only use fuels and oils of the appropriate classification in the engines, or fuels and oils recommended by the branded dealer. Damage caused by the use of unsuitable fuels and oils will not be covered under warranty.